



SERVICE MANUAL

A101 ACE-BASS STEREO AMPLIFIER

FRONT PANEL

- 1. Power
- 2. Phones
- 3. Speaker Selector
- 4. Bass
- 5. Treble
- 6. Bass EQ
- 7. Infrasonic Filter
- 8. Mono
- 9. Tape Monitor
- 10. Input Selector
- 11. Low Level
- 12. Loudness
- 13. Volume/Balance

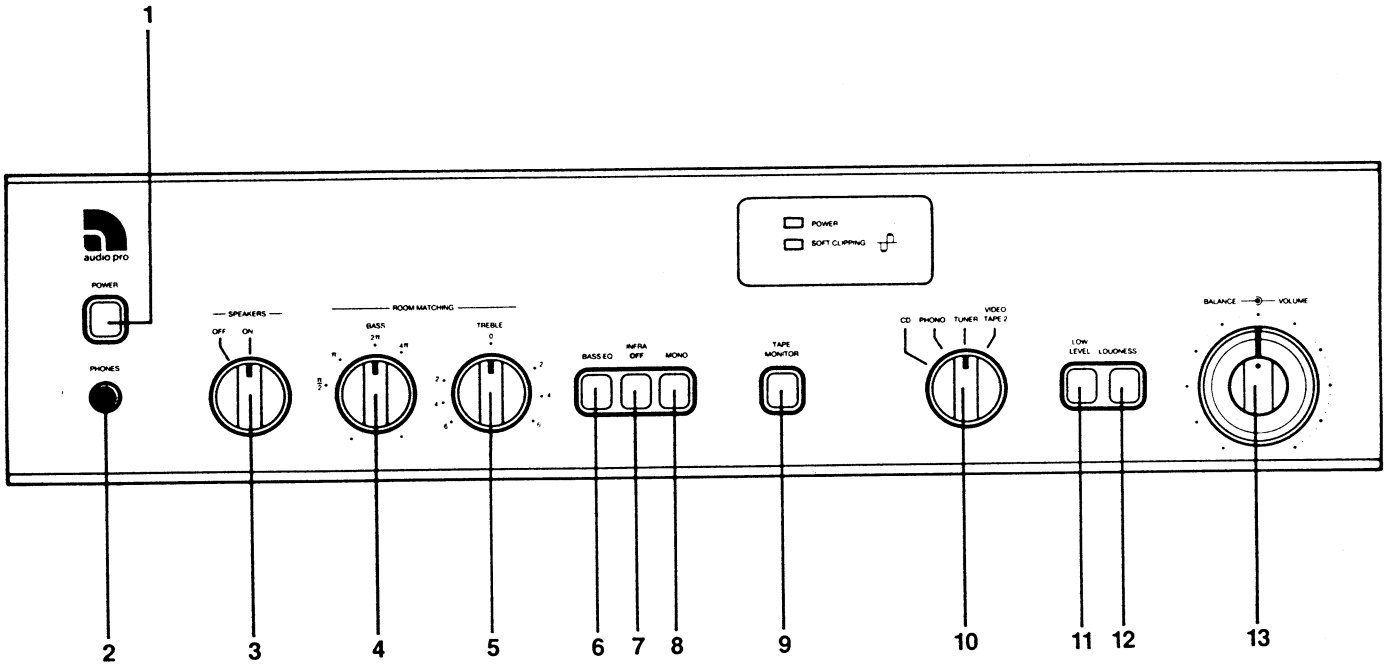

REAR PANEL

- 1. AC Line Cord
- 2. Speaker Right
- 3. Speaker Left
- 4. Phono Ground
- 5. Phono Input
- 6. Tuner Input
- 7. CD Input
- 8. Video Input
- 9. Tape Input/Output
- 10. Preamp out/Main in
- 11. Soft Clipping
- 12. Soft Clipping

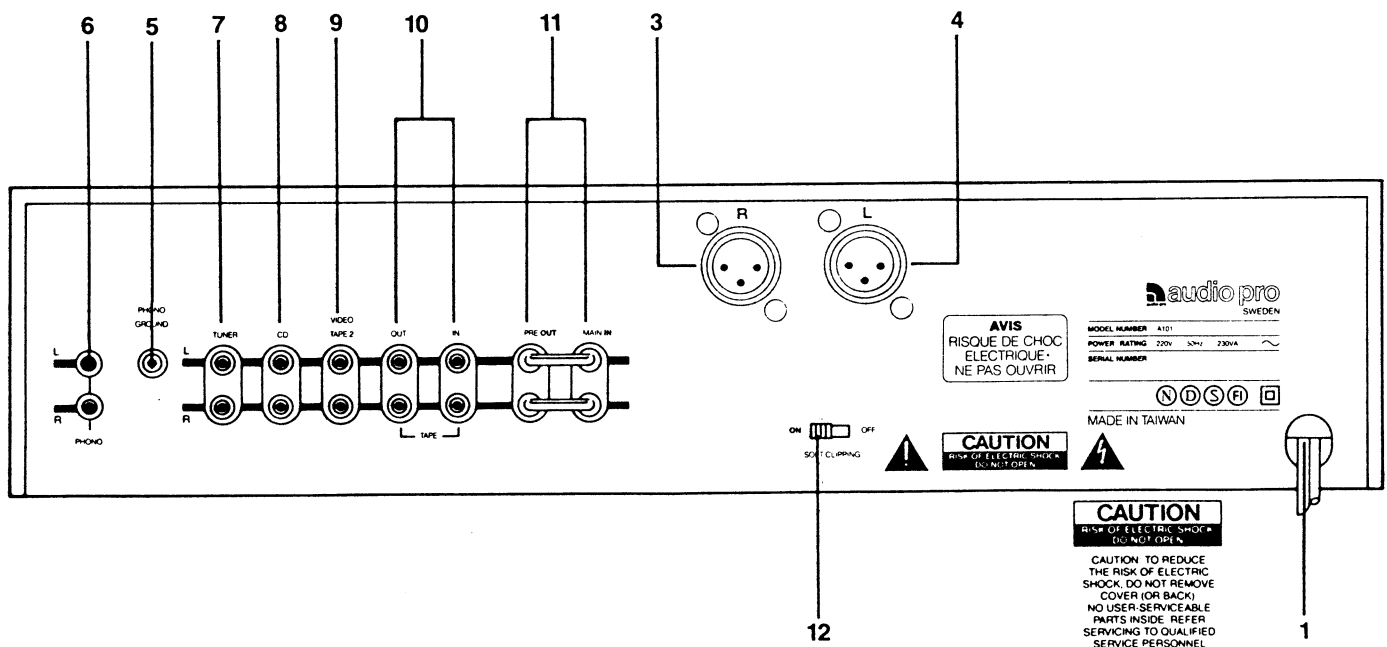

A101 ACE-BASS STEREO AMPLIFIER

MAIN AMPLIFIER ALIGNMENT

A. CENTER VOLTAGE ADJUSTMENT

- 1) Connect DVM across L channel (R channel) output terminals.
- 2) Turn on, and adjust VR-401 (VR-402) for reading of $0V \pm 30mV$ DC.

B. IDLE CURRENT ADJUSTMENT

- 1) Remove solder short across R-471 and R-472.
- 2) Connect DVM across R-471.
- 3) Turn on and adjust VR-403 for reading of $28mV \pm 2mV$ DC.
- 4) Repeat, using R-472, adjust VR-404.

C. FINAL ADJUSTMENT

- 1) Leave power on minimum 5 minutes.
- 2) Repeat center voltage and idle current adjustments.
- 3) When finished, replace solder short across R-471 and R-472.

ACE-BASS CIRCUIT ALIGNMENT

IMPORTANT NOTE:

There are two different versions of the A101 amplifier. One for the A2-2 speaker and another one for the A2-5 speaker.

It is possible to convert the versions by moving all jumpers on the ACE subboard AND by realigning the ACE-bass circuit.

All jumpers shall be in the position towards front panel for A2-2.
All jumpers shall be in the position towards rear panel for A2-5.

ADJUSTMENT:

- 1) Disconnect the speaker cables so the amplifier is unloaded.
- 2) Connect a sine wave generator to a high level input and an AC-voltmeter to the speaker output of the L channel (R-channel) of the A101 amplifier.
- 3) Set the generator frequency to $70 \text{ Hz} \pm 2 \text{ Hz}$.
- 4) Set the volume so the speaker output level between pins 1 and 2 is:
 - 330 mV (-7.4 dBm) for the A2-2 version.
 - 456 mV (-4.6 dBm) for the A2-5 version.
- 5) Load the speaker output with a $6.8 \text{ ohm} \pm 5\%$ resistor. (Insert the resistor between pins 1 and 2 in the XLR-connector.)
- 6) Adjust VR801 (VR701) until the level reaches 775 mV (0dBm) at the speaker output. (I.e. the output level shall increase by 7.4 for A2-2 and 4.6 dB for A2-5 when loaded with the 6.8 ohm resistor.)

Repeat the procedure for the other channel.

- 7) Connect the speakers and test the amplifier. There should be no sign of instability when gently pushing the woofer cones.

* In some versions of the amplifier the ACE-Circuit PCBs for left and right channel have same component markings. See page 6.

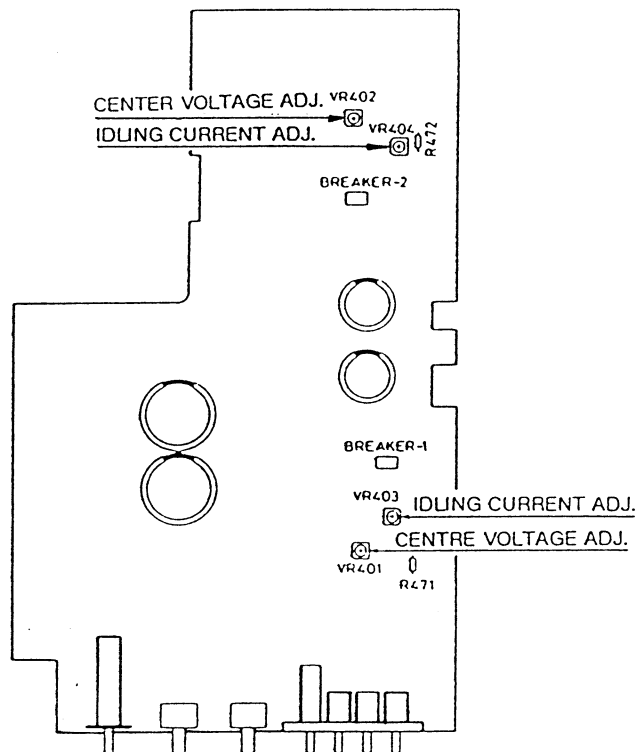

XLR-connector
seen from outside

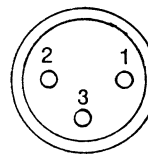

POWER AMPLIFIER PCB

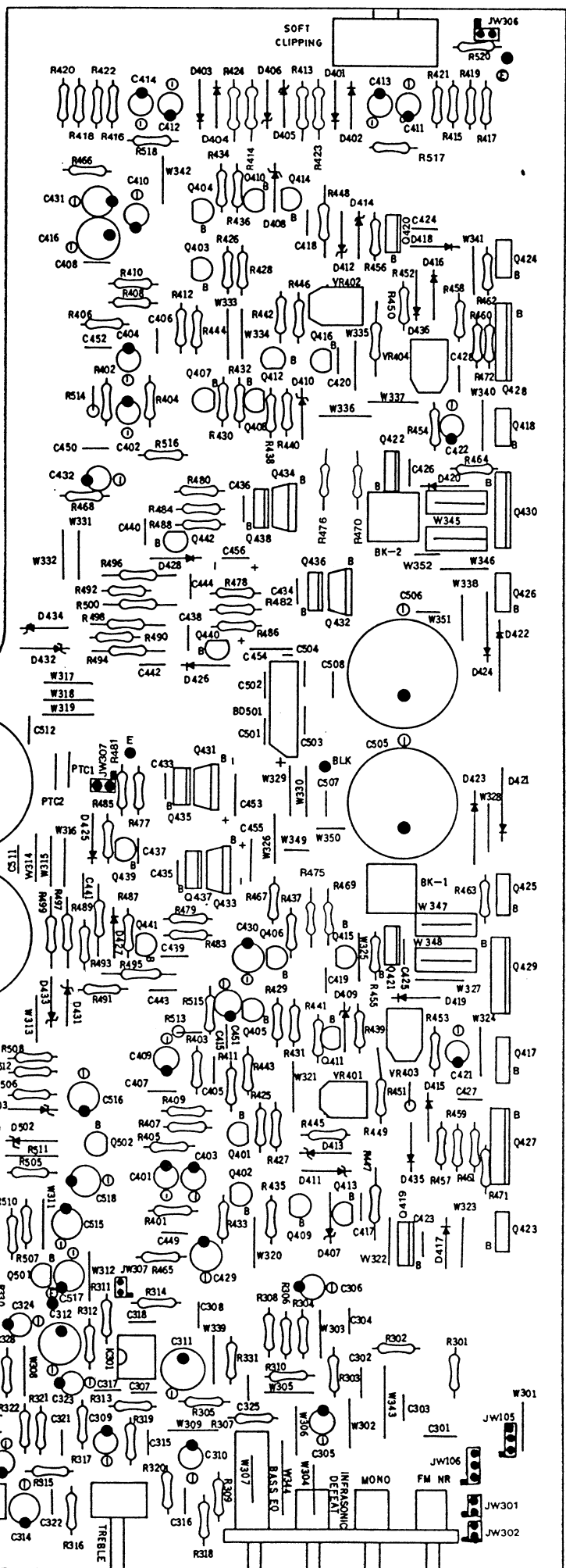
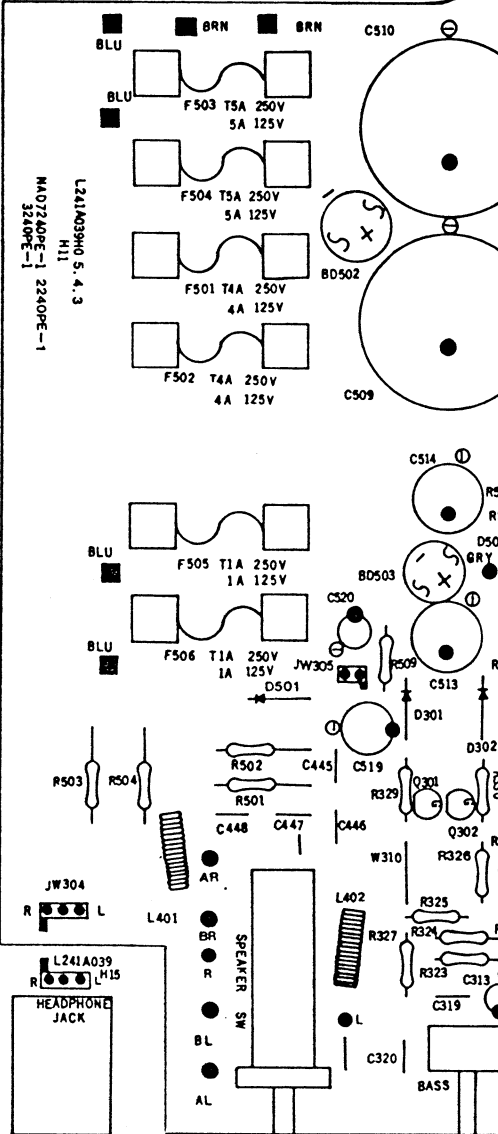
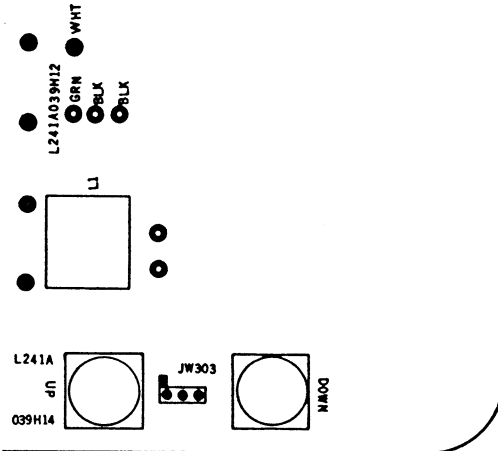
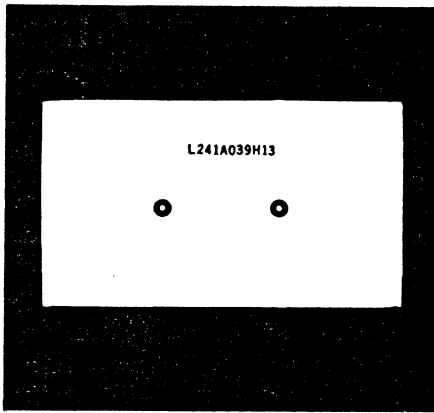

SPEAKER CONNECTION PCB

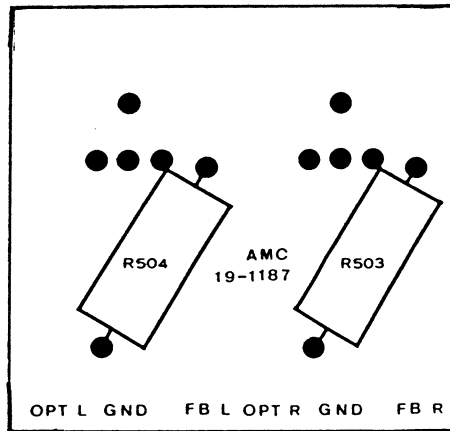

LED PCB

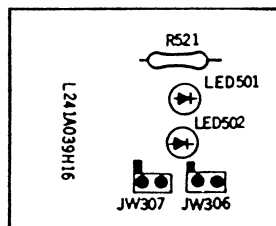

PREAMPLIFIER FRONT PCB

ACE-CIRCUIT PCB

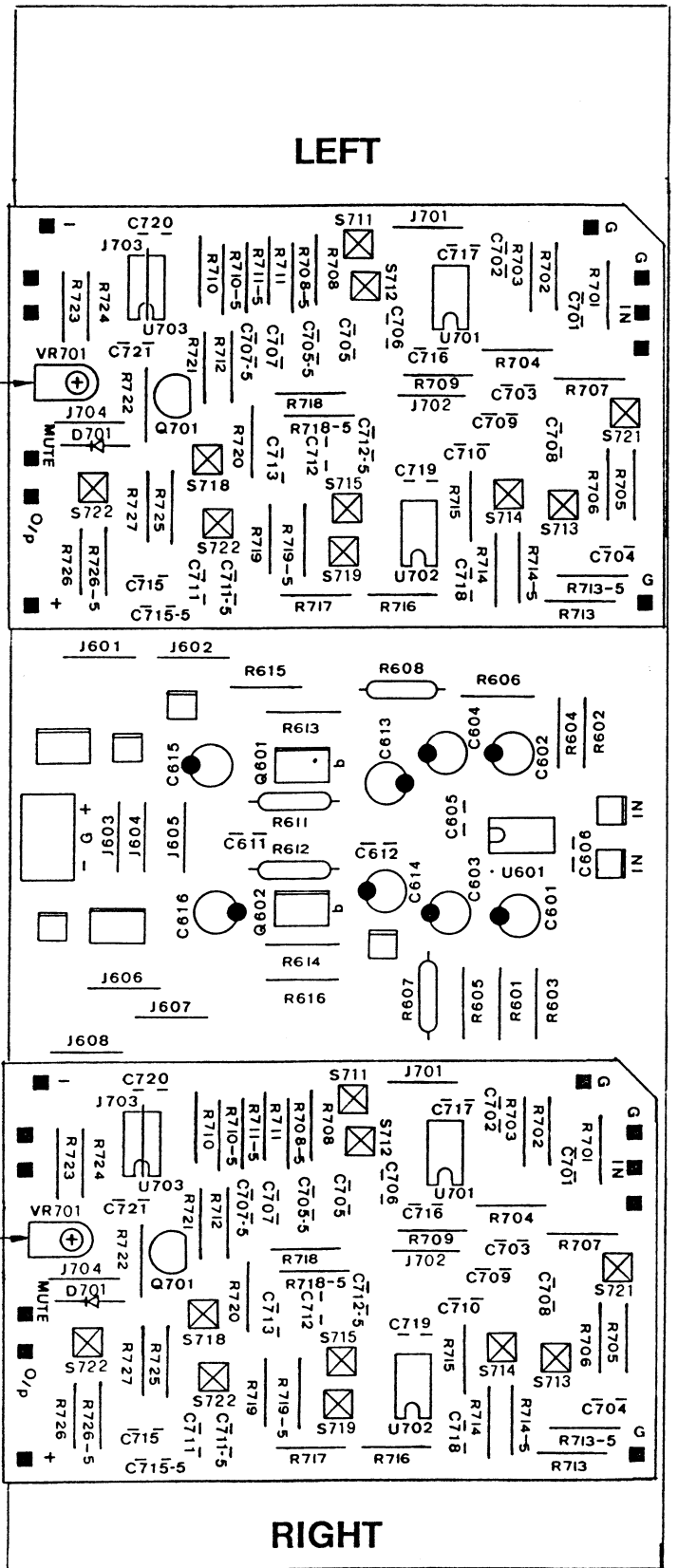
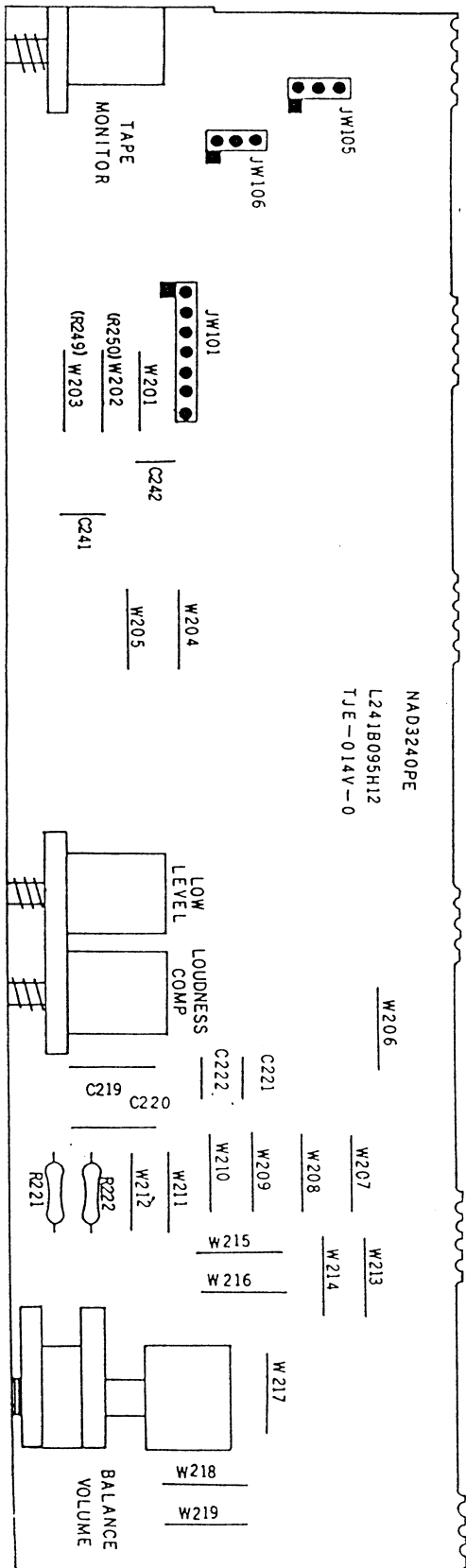

⊠ Jumper connector

PREAMPLIFIER REAR PCB

REAR PANEL

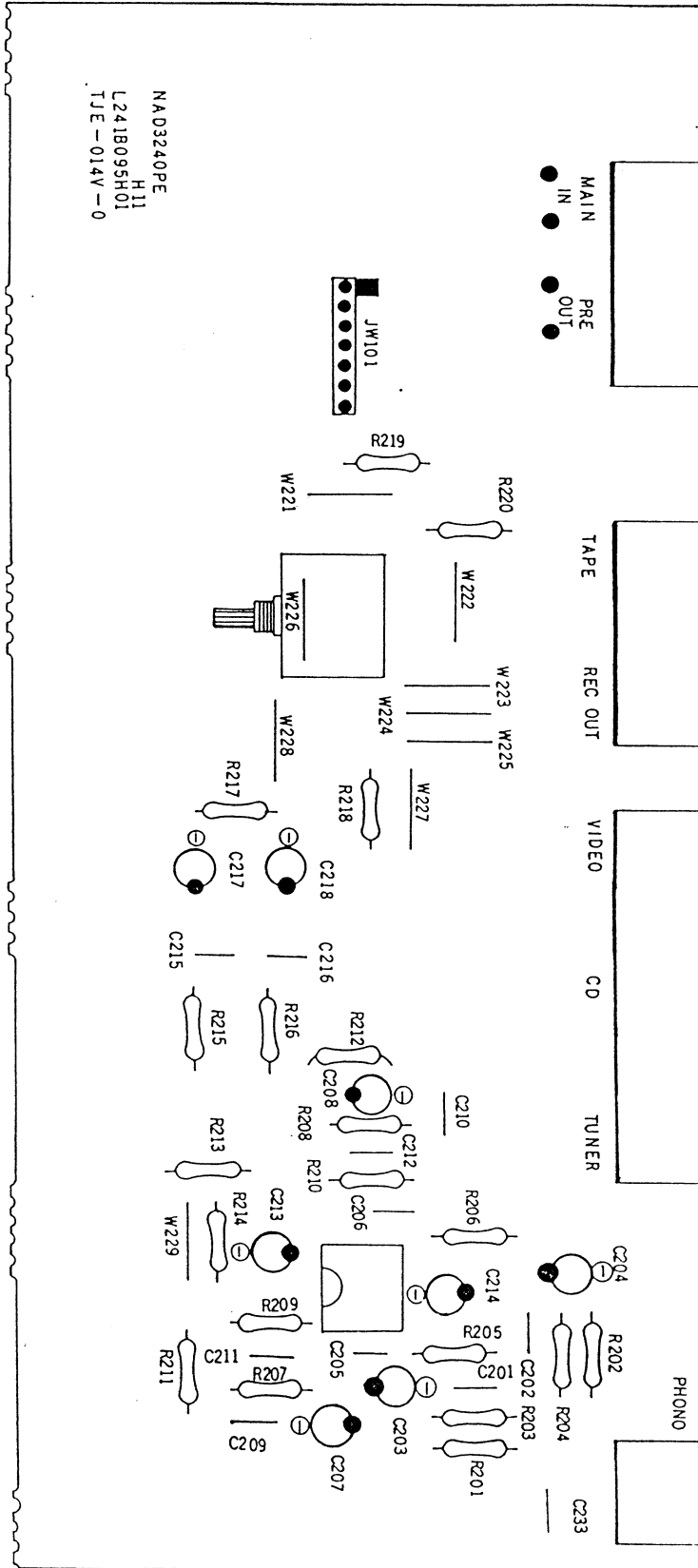

SCHEMATIC DIAGRAM AUDIO PRO A101 AMPLIFIER

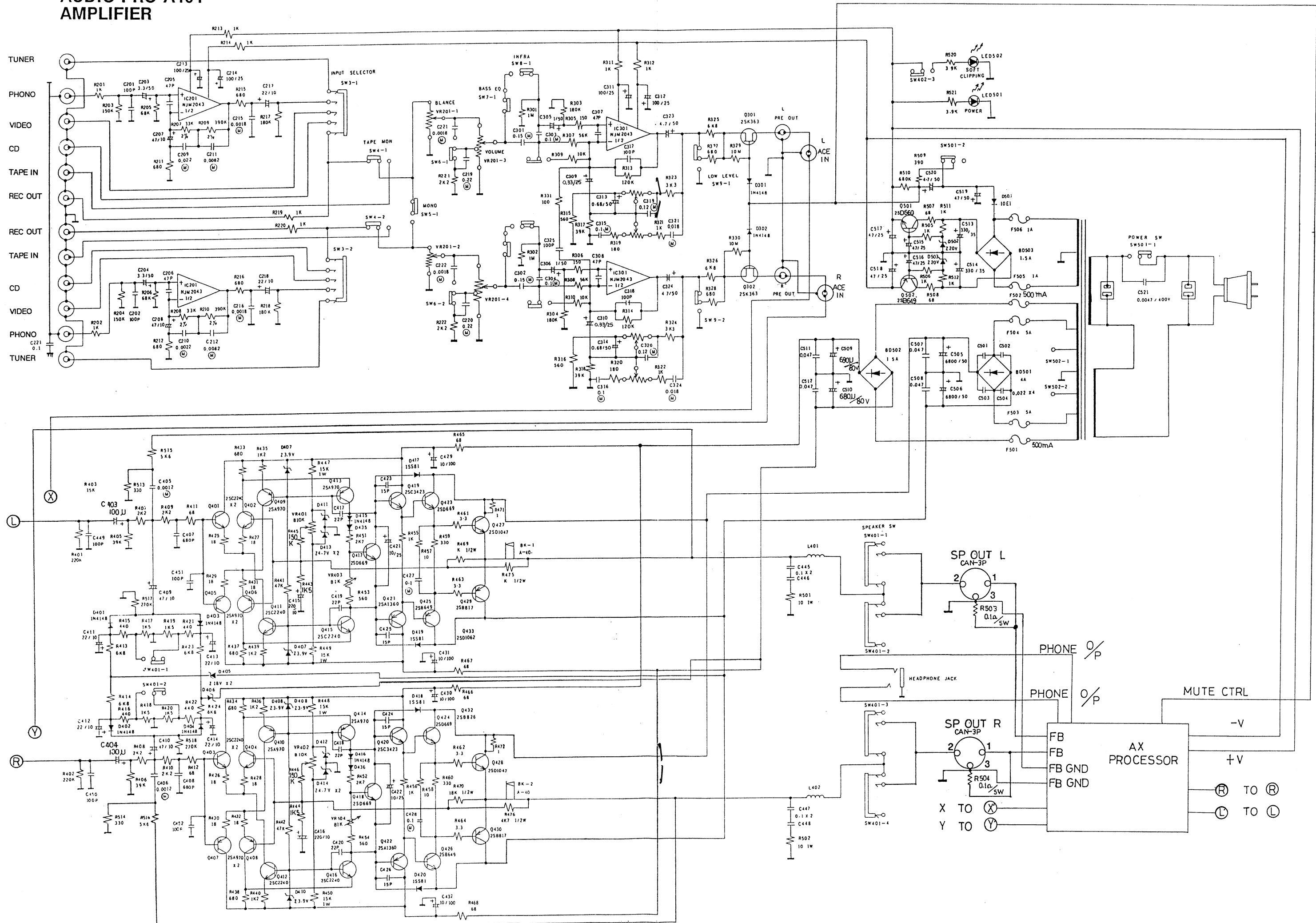

SCHEMATIC DIAGRAM ACE CIRCUIT

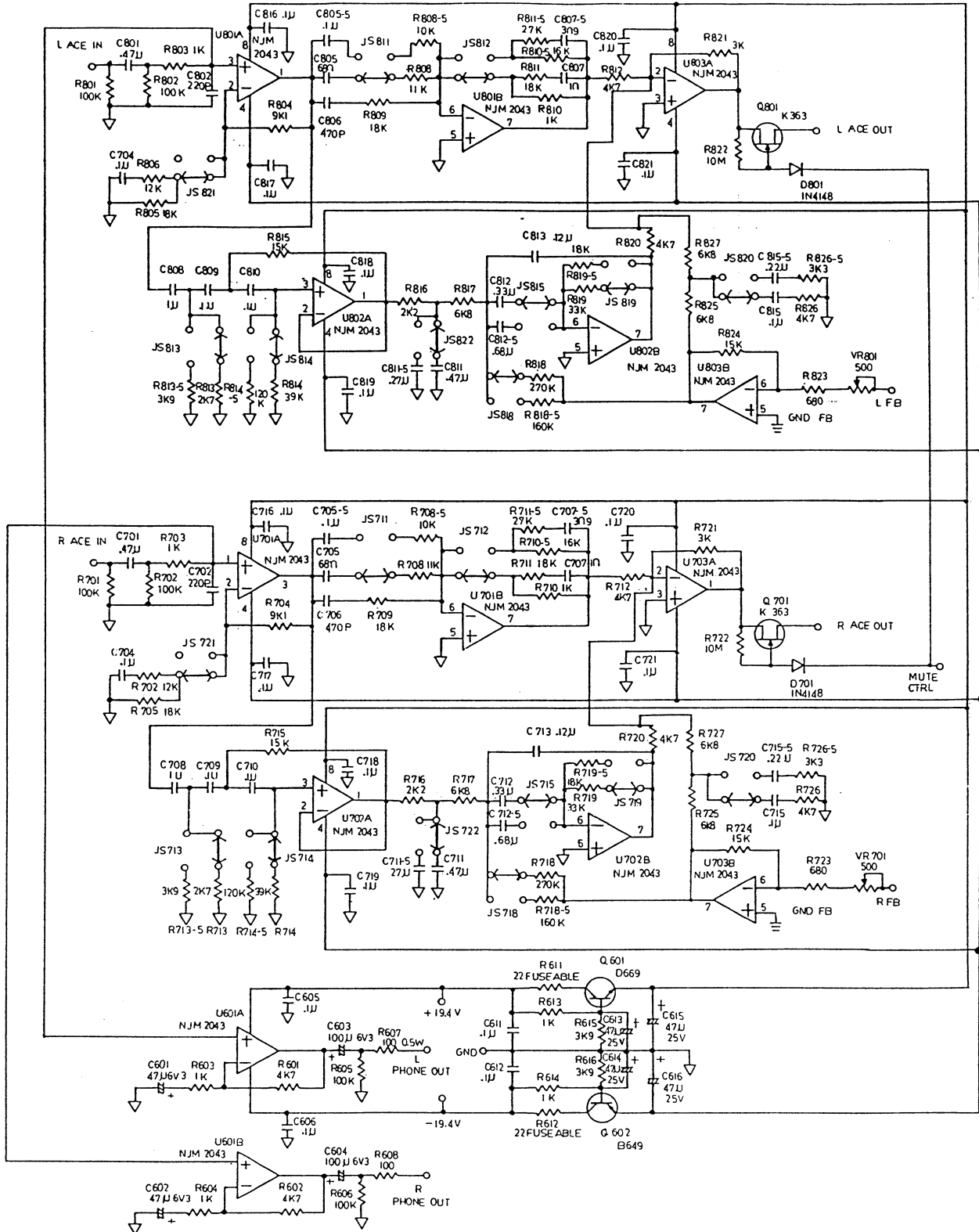

EXPLODED VIEW

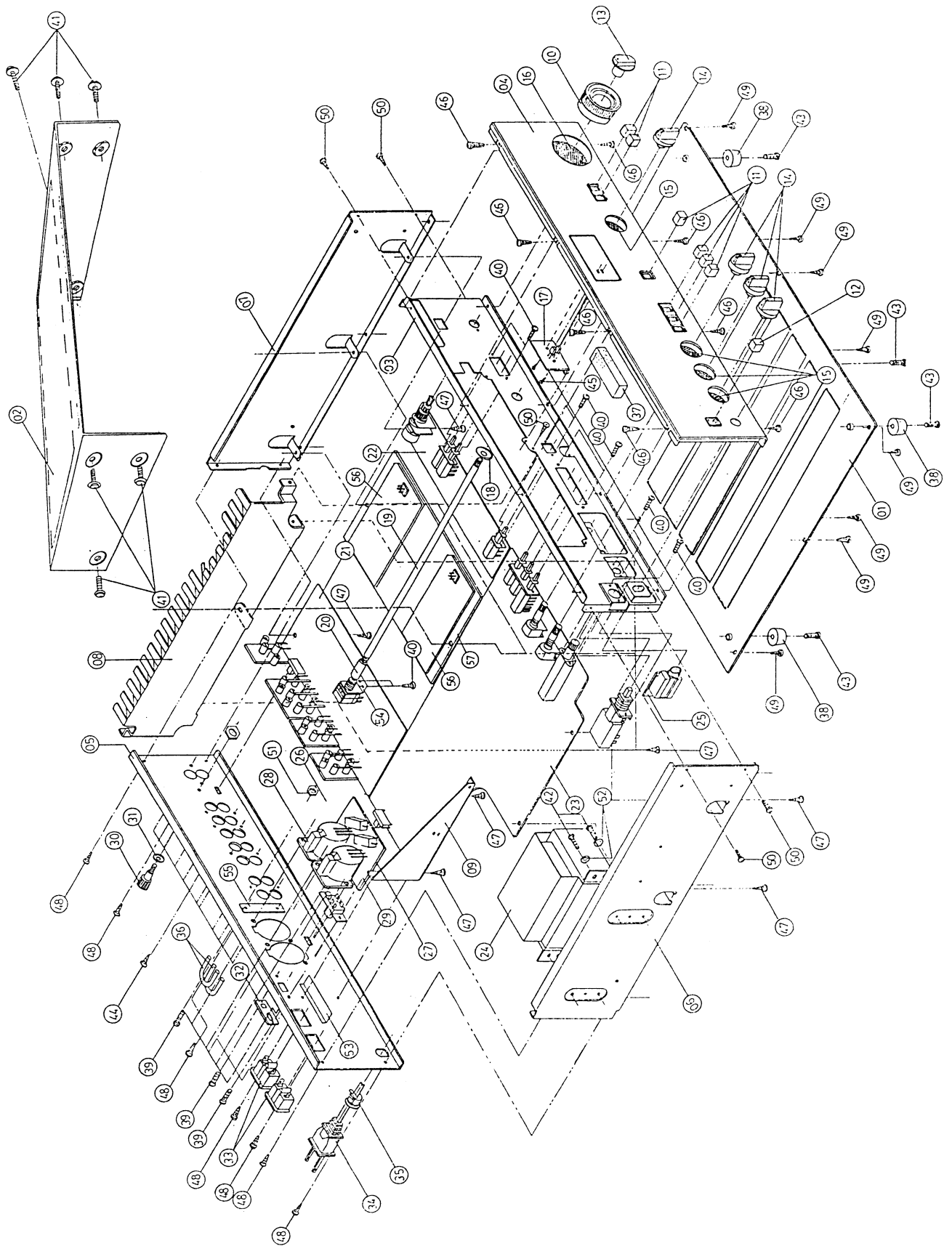

EXPLODED VIEW PARTS LIST

NO	PARTS NO	NAME	QTY
1	11-6317	COVER BOTTOM	1
2	50-1035	CABINET	1
3	11-6127	CHASSIS, FRONT SUB	1
4	11-8388	PANEL, FRONT	1
5	11-8389-1-2-3	PANEL, REAR	1
6	11-6128	FRAME L	1
7	11-6129	FRAME R	1
8	11-5067	HEAT SINK	1
9	11-2336	BRACKET, PCB SUPPORT	1
10	12-3123	KNOB, VOLUME	1
11	12-3121	KNOB, FUNCTION	6
12	12-3122	KNOB, POWER	1
13	12-3124	KNOB, BALANCE	1
14	12-3140	KNOB, ROTARY	4
15	28-2072	RING, FELT TONE CONTROL	1
16	28-2071	RING, FELT VOLUME CONTROL	3
17	19-1188	PCB, LED	1/3
18	12-3125	BEARING, SHAFT	1
19	11-7037	SHAFT	1
20	12-1084	SLEEVE, INPUT, SELECTOR SWITCH	1
21	11-1189	PCB, INPUT	1/2
22	19-1189	PCB, VOLUME	1/2
23	19-1188	PCB, MAIN	1/3
24	29-2124	TRANSFORMER	1
25	19-1188	PCB, PHONE JACK	1/3
26	12-2092	JACK, RCA 4P	2
27	12-2093	JACK, RCA 6P	1
28	12-2131	JACK, SPK	2
29	19-1187	PCB, SPK	1
30	15-2037	SCREW, GROUND	1
31	A3.5A09SN01	WASHER GROUND $\phi 3.5 * \phi 9 * 1t$	1
32	12-2107	JACK, RCA 2P	1
33	12-2122	AC SOCKET	2
34	14-5028	AC CORD	1
35	14-5008	CLAMPER	1
36	11-4007*B	BAR LINK	2
37	28-2073	CUSHION SPONGE	1
38	28-1044	FOOT RUBBER	4
39	S1B03+I06SL-2	SCREW MECH M3*6	4
40	S1B03+I06SL2	SCREW MECH M3*6	10
41	15-2062	SCREW MECH M4*8 WITH WASHER	6
42	S1B04+I08SL2	SCREW MECH M4*6	4
43	S1B04+I06SL-2	SCREW MECH M4*6	4
44	S2B03+I08SL-2	SCREW TAPPING T3*8	10
45	S2B03+I06SL2	SCREW TAPPING T3*6	2
46	S2B03+I06SL2	SCREW TAPPING T3*6	8
47	S2B03+I06SL2	SCREW TAPPING T3*6	10
48	S2B03+I06SL2	SCREW TAPPING T3*6	7

NO	PARTS NO	NAME	QTY
49	S2B03+I08SL2	SCREW TAPPING T3*8	8
50	S2B03+I08SL2	SCREW TAPPING T3*8	4
51	19-1185	PCB, ACE BASS	2
52	A04G10SZ2.5	WASHER GEAR $\phi 4$ * $\phi 10$ * 2.5t	1
53	13-4082	COVER AC SOCKET	1
54	19-1184	PCB ASSY	1
55	13-4084	SHEET ISOLATING	1

PACKING

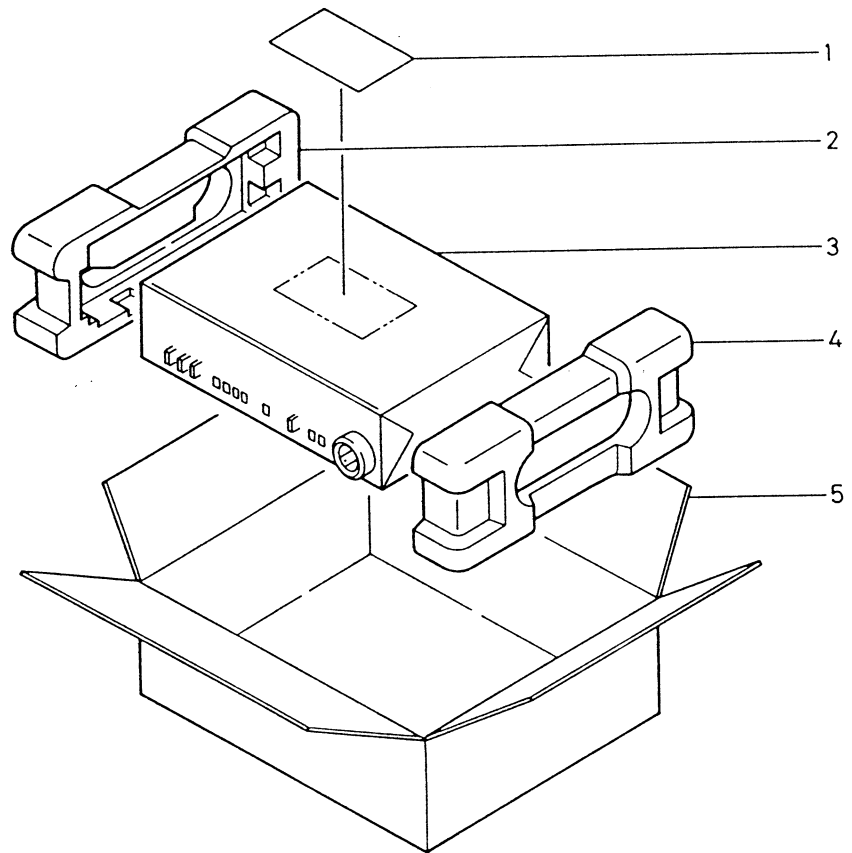

<u>ITEM</u>	<u>NAME</u>	<u>QTY</u>
1	Instruction	1
2	Styrofoam, Left	1
3	Poly-bag	1
4	Styrofoam, Right	1
5	Box	1

SPECIFICATIONS

Power Amplifier Section

Continuous average power output at 8 ohms	2 x 50 w
Rated distortion (THD) 20Hz-20kHz	0.03%
Slew factor	> 50
Slew rate	15V/ μ sec
THD and SMPTE.I.M distortion from 250 mW to rated output	0.03%
Input Impedance	47kohm
Input Sensitivity	600mV for 96dB SPL, 1m, 2 π

Preamplifier Section

Phono Input	
Input Impedance	R=47kohm, C=100pF
Input Sensitivity (1kHz)	2mV for 96dB SPL, 1m, 2 π
Signal-to-Noise Ratio with cartridge connected, A-weighted	76dB re 5mV
Input Overload at 20 Hz/1kHz/20kHz	20/180/1500mV
RIAA Accuracy	\pm 0.5dB
High-Level Inputs (CD, Video, Tape)	
Input Impedance	R=15kohm, C=100pF
Input Sensitivity	100mV for 96dB SPL, 1m, 2 π
Signal-to-Noise ratio A-weighted	98dB rel 100mV in
Input Overload	10V
Frequency Response	20Hz-20kHz \pm 0.5dB
Outputs	
Preamp output impedance	600ohm
Tape output impedance	Source Z+1000ohm
Controls	
Treble Room matching	\pm 7dB at 10kHz
Bass Room matching	$\pi/2$ - 4 π (ca \pm 6dB at 50Hz)
Bass Equalization Pushbutton	+3dB at 70Hz +6dB at 40Hz
Infrasonic Filter	-3dB at 12Hz 12dB/octave
Low Level (audio muting)	-20dB
Physical Specification	
Width x Height x Depth	42 x 10.8 x 38 cm 16.5 x 42.5 x 15 in
Net Weight	6.7kg (14 lbs 14 oz)
Shipping weight	8kg (17 lbs 12 oz)
Power Consumption	50/60Hz at 110, 120, 220 or 240 VAC 200W

Specifications are those in effect at the time of printing Audio Pro reserves the right to change specifications or designs at any time without notice.



audio pro

Audio Pro AB, Box 65, S-568 00 Skillingaryd, Sweden